







DH20 Dehumidifier



English Manual

Instructions

-  Do not use with wet hands
-  Follow the instructions
-  Disconnect from outlet after use
-  Do not open
-  Do not touch
-  Warning/Caution

Power Supply

- Always hold the plug and pull to disconnect from the wall outlet.
- Do not touch the plug with wet hands in order to avoid electric shock.
- The appliance must be plugged specifically into a 220v socket.
- Do not use with extension cords.
- Do not attempt to change the power cord.
- If there is an electrical problem, please contact your seller/original place of purchase.

Installation

- Always place the appliance on a solid, flat and stable surface.
- Make sure the water tank is correctly installed into its compartment.
- Do not put flammable or explosive objects near the appliance in order to avoid fire hazards.

Operation

- Children must be supervised near the appliance to ensure their safety.
- Elderly must be supervised near the appliance to ensure their safety in order to avoid a lack of oxygen near the air outlet.
- Do not put hands on the air outlet in order to prevent injury or malfunction.
- Do not put clothes on the air outlet in order to prevent malfunction.
- Do not push the appliance over or let the appliance be exposed to high impacts in order to prevent damage/malfunction.
- Do not put any heavy objects or cover the appliance.

Cleaning

- Do not pour water into the appliance, always use a damp cloth.
- Clean the air filter regularly with a damp cloth and mild cleaning fluid to avoid dust build-up.
- Do not put chemicals on the appliance in order to avoid fire.

Parts List

Front



Back



Control & Display Panel

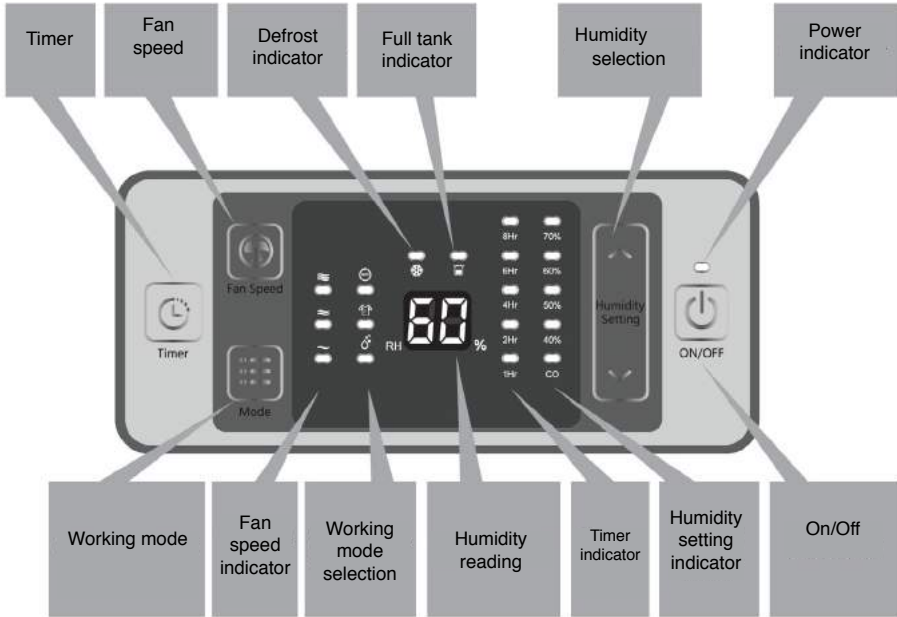

1.  ON/OFF: Press once to turn the unit ON or OFF.
2. “^” Up
“v” Down

Under manual operation mode, used to set the target humidity and adjustment time, the humidity could be set between 40%-70% in 10% per step or “CO”. When the humidity is set to “CO”, the machine will work continuously. The timer can be set to 1h-2h-4h-6h-8h and can be used to shut down after timer.

Note: A keylock program is designed for this unit, press “^” and “v” at the same time for 2 seconds and all the keys on the panel will be locked. To release the lock, repeat the same action.

3.  key: Used to change the different working modes, press once to change the mode among automatic dehumidifying - clothes drying and dehumidifying.

4.  key: Used to change the fan speed from high, medium and low.

Note: In automatic mode, this key is invalid.

5.  key: Used to set the timing shutdown. To use, please read the operation instructions.

LED Indicator

1. Fan speed indicator:

When the unit runs at high speed, “” will be on.

When the unit runs at medium speed, “” will be on.

When the unit runs at low speed, “” will be on.

2. Working mode indicator:

When the unit works at different modes, the relative indicator will be on:



3. Defrosting indicator:

When the unit begins to defrost, “” will be on.

4. Water tank full indicator:

When the water tank is full, the unit will go into standby mode.  Will begin to flash at a high frequency.

5. Humidity setting indicator:

When you set the humidity, the corresponding indicator lights will appear:



6. Timing shutdown:

When you set the time, the corresponding indicator lights will appear:



7. Operating Indicator:

When you turn the appliance on, the indicator will stay on. When you turn the appliance off, the indicator will slowly flash before turning off completely.

Before Use

1. Place the unit in a suitable location for best operating conditions.

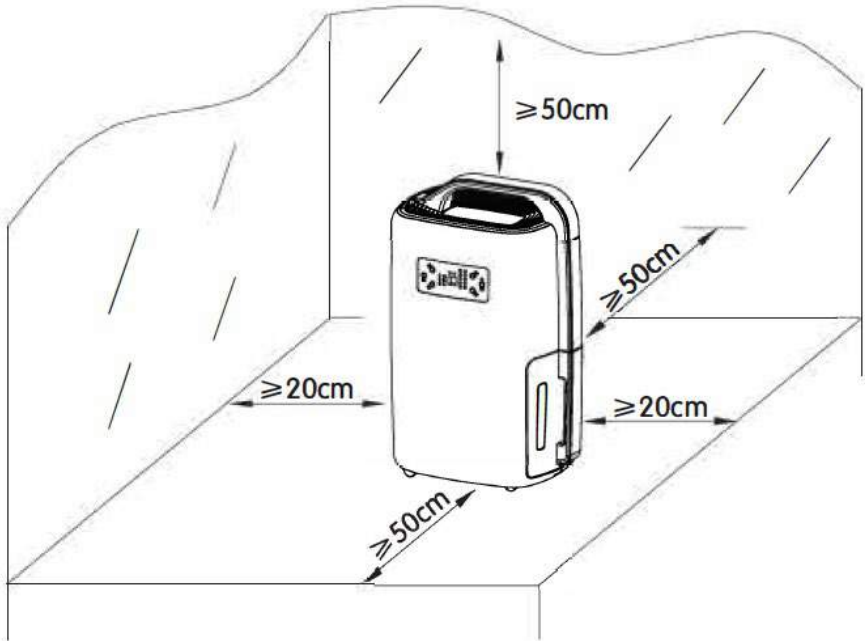

2. Please make sure your household voltage corresponds with the rating label of the dehumidifier.
3. Check and make sure the inlet and outlet are not blocked by other objects.
4. If you wish to use the dehumidifier for a long period of time, use the drainage pipe, so you do not have to continuously empty the water tank.

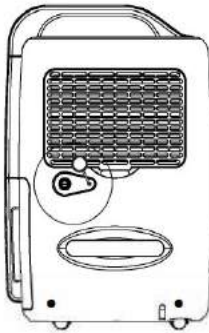

Figure 1



Take off plug

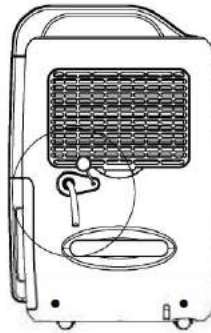
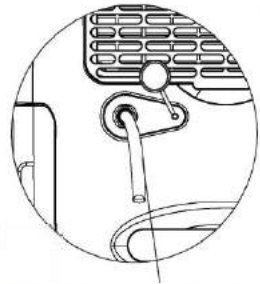



Figure 2



Plug drainage pipe with 14mm inner diameter in the hose connector

Note: Gently stretch the drainage pipe if it is squashed or twisted, otherwise drainage will be restricted and the unit will not work normally. During the operation, drainage pipe should never be in a higher position than the hose connector.

How To Use

1.  ON/OFF: Press once to turn unit ON or OFF.
 - a. Press “ON/OFF” once and the unit will begin to work.
 - b. Press “ON/OFF” once again after use and the unit will shut down.

Note: Let the unit rest for about 3 minutes after turning off, so that residual water on condenser can flow into the tank. Pull out the plug when the unit is off for power saving and safety.

2. “^” Up
“v” Down

Humidity can be set by pressing keys “^” and “v” (40%--50%--+ 60%-70%-CO) press “Up” or “Down” once, the set value will increase or reduce 10%, “CO” will then appear on the panel and the unit will operate continuously. When the humidity setting has finished and there is no operation, the unit will accept the setting and the indicator light will stay illuminated.

3. . “  ” Timer

The time can be set among 1h-2h-4h-6h-8h. If you wish to cancel the timer, press and hold the timer button for 3 seconds and it will cancel.

4. “  ” Fan speed

You can adjust the speed of the fan by pressing the ‘fan speed’ button. You can choose between high, medium and low. If the dehumidifier mode is set to automatic, the speed cannot be adjusted.

5. “  ” Mode”

During operation, press this key to change the working mode, as follows:
automatic dehumidifying > clothes drying > dehumidifying.

Dehumidifying mode: can set humidity manually.

Automatic mode:

Rh>60%, high speed fan and dehumidifying;

60%>RH>55%, medium speed fan and dehumidifying;

Rh<55%, low speed fan and no dehumidifying.

Clothes drying mode; under the default of high speed wind state, the unit will automatically shut down after 6 hours of continuous operation.

Care & Maintenance

Cleaning Machine Body

Clean the machine body with a soft, dry cloth. If the device is extremely dirty, use a mild cleaning agent. Wipe the dehumidifier with a slightly damp cloth. Never spray water on the device.



Cleaning Air Filter

Remove the filter. Clean the filter with a vacuum cleaner or damp cloth (no warmer than 40°C). Rinse and dry completely before inserting back into the dehumidifier.



Cleaning Air Inlet

Please remove the air filter first. Then, clean the air inlet with a vacuum cleaner or a soft, dry cloth.



Troubleshooting

Problem	Cause	Solution
Unit does not operate	Unit power cord is unplugged	Disconnect the plug and connect it again or please check if outlet is properly functioning.
	Unit has not been turned on.	Turn on the switch.
	The water light is flashing.	Water tank is full, empty the tank; make sure the tank is correctly placed back into the compartment.
Dehumidifying capacity is low	Runtime is too short.	Increase the operation time using the timer function.
	Air filter is dirty and/ or obstructed.	Use water and a damp cloth to clean the filter.
	Ambient room temperature or humidity is too low.	Dehumidifying capacity is normally lower if the room temperature is below 18°C. please try to increase the room temperature.
	Humidity setting is higher than the ambient humidity	Set the humidity down and lower than the ambient humidity.
	Drainage water pipe is blocked or flat.	Check the water pipe and replace it if necessary.
Relative Humidity setting not reached after long period of operation.	Windows and doors are not closed or sealed.	Close the door and window or enclose the space.
Water is leaking	The unit is not placed on a flat stable surface.	Place the unit on a flat and stable surface.
Outlet air is warm	Heat exchanging process	This is normal
Water noise	Refrigerating fluid is flowing.	This is normal

Warranty

1 Year Guarantee from Shine-Mart Ltd, Trademark owners of Duronic Products.

NOTE: THESE STATEMENTS DO NOT AFFECT YOUR STATUTORY RIGHTS AS A CONSUMER

This product has been manufactured under the strictest or quality control procedures, and using the highest quality of materials, to ensure excellent performance and reliability. It will give very good and long lasting service, provided it is properly used and maintained. The product is guaranteed for 1 years from the date of original purchase. If any defect arises due to a faulty materials or poor workmanship, the faulty product must be returned to the original place of purchase. Refund or replacement is at the discretion of that company. Duronic Products are offered with a 1 year guarantee under the following conditions:

1. The product must be returned to the retailer with original proof of purchase.
2. The product must be installed and used in accordance with the instructions contained in this operating manual.
3. It must be used only for domestic purposes.
4. It does not cover wear and tear, malicious damage, misuse, neglect, inexpert repairs or consumable parts.
5. Shine-Mart Ltd has no responsibilities for accidental or consequential loss or damage.
6. Shine-Mart Ltd are not liable to carry out any type of servicing work, under the guarantee
7. Valid in the UK only



This product is fitted with CE:1363 plug and fuse
Imported by Shine-Mart Ltd, RM3 8SB



Information on waste Disposal for Consumers of
Electrical & Electronic Equipment.

This mark on a product and/or accompanying documents indicates that when it is to be disposed of, it must be treated as Waste Electrical & Electronic Equipment, (WEEE).

Any WEEE marked products must not be mixed with general household waste, but kept separate for the treatment, recovery and recycling of the materials used. For proper treatment, recovery and recycling; please take all WEEE marked waste to your Local Authority Civic waste site, where it will be accepted free of charge.

If customers dispose of Waste Electrical & Electronic Equipment correctly, they will be helping to save valuable resources and preventing any potential negative effects upon human health and the environment, of any hazardous materials that the waste may contain.

Follow Us



duronicon.com



[duronicon](https://www.youtube.com/channel/UCduronicon)



[@duroniconmedia](https://www.instagram.com/duroniconmedia)



[Duronicon](https://www.facebook.com/duronicon)



[@duroniconmedia](https://twitter.com/duroniconmedia)